

Datasheet

Subject to technical alteration
Issue date: 03.05.2021 • A118



» APPLICATION

Bidirectional gateways with serial interface RS485 in IP65 enclosure. For connecting EasySens sensors or wireless switches to various controller models with RS485 interface. Transmission of custom programmable telegrams, incl. external receiving antenna (2.5 m).

» TYPES AVAILABLE

EasySens Gateways

STC65+ RS485-Modbus
STC65+ RS485-EVC

» SECURITY ADVICE – CAUTION



The installation and assembly of electrical equipment should only be performed by authorized personnel.

The product should only be used for the intended application. Unauthorised modifications are prohibited! The product must not be used in relation with any equipment that in case of a failure may threaten, directly or indirectly, human health or life or result in danger to human beings, animals or assets. Ensure all power is disconnected before installing. Do not connect to live/operating equipment.

Please comply with

- Local laws, health & safety regulations, technical standards and regulations
- Condition of the device at the time of installation, to ensure safe installation
- This data sheet and installation manual

» NOTES ON DISPOSAL



As a component of a large-scale fixed installation, Thermokon products are intended to be used permanently as part of a building or a structure at a pre-defined and dedicated location, hence the Waste Electrical and Electronic Act (WEEE) is not applicable. However, most of the products may contain valuable materials that should be recycled and not disposed of as domestic waste. Please note the relevant regulations for local disposal.

» PRODUCT TESTING AND CERTIFICATION



Declaration of conformity

The declaration of conformity of the products can be found on our website <https://www.thermokon.de/>.

» INFORMATION ABOUT EASYSSENS® (RADIO) / AIRCONFIG GENERAL USAGE



EasySens® - airConfig

Basic information about EasySens® radio and about general usage of our airConfig software, please download from our website.

» OVERVIEW OF THE RADIO TELEGRAMS



EEP

The structure of the data contained in the telegram can be found in the EEP (EnOcean equipment profile) list provided by the EnOcean Alliance.

» INFORMATION ABOUT SMART ACKNOWLEDGE (SMARTACK)



This bi-directional communication mechanism also allows the building system to send back data to a sensor, i.e. to overwrite SR06LCD's set point. Smart Acknowledge requires that both communication devices do support the Smart Acknowledge mechanism.

Communication must be performed directly with a SmartACK capable receiver, e.g. STC65-FTT LON (SMACK special version) or STC65+ RS485 Modbus/EVC. Repeaters are not supported, they delay in the telegram transmission. Sensor and gateway must communicate directly with each other.

Additional Information of the used EEP's with Smart ACK can be found using the following link:

[→ Download PDF](#)

» TECHNICAL DATA

Network technology	RS485	
Communication protocol <i>type-dependent</i>	Modbus (RTU / ASCII) or EVC RS485 bus load: 1 unit load according to RS485 standard (max. 32 devices)	
Radio technology	EnOcean (IEC 14543-3-10), transmission power <10 mW	
Frequency	868 MHz	
Antenna	external transmit- / receive antenna	
Data transmission	bidirectional	
Receive- transmit channels <i>type-dependent</i>	Modbus 32 (Rx) + 32 (Tx) + 32 (VA)	EVC filter-mode: 64 (Rx), gateway-mode: ∞ (Rx) filter-mode: 128 (Tx), gateway-mode: 128 (Tx)
Power supply	15..24 V = (±10%) or 24 V ~ (±10%) SELV	
Power consumption	typ. 0,8 W (24 V =) 2 VA (24 V ~)	
Enclosure	enclosure USE-M, PC, pure white, cover PC, transparent	
Protection	IP65 according to EN 60529	
Cable entry	M25, for wire max. Ø=7 mm, seal insert for fourfold cable entry	
Connection electrical	terminal block, max. 1,5 mm ²	
Ambient condition	-20..+60 °C, max. 70% rH non-condensing	
Weight	without antenna 110 g	
Delivery content	external transmit- / receive antenna	
Notes	up to 15 devices with Smart Acknowledge (SmartACK), magnetic antenna holder required for better radio range	

» MOUNTING ADVICES

The module enclosure can be mounted directly onto a DIN top-hat rail using the mounting base or surface-mounted using dowels and screws.

- The antenna should be mounted at metallic objects, e.g. at an air tube behind a false ceiling or at an 180 mmx180 mm metal plate (material: galvanized sheet steel, see accessories).
- In rooms the antenna should be at least 10 cm away from the ceiling.
- The antenna should be vertically aligned downwards.
- Minimal distance to the wall: 10 cm.
- Distance to other transmitters (e.g. GSM/ DECT/ wireless LAN/ EnOcean sender): at least 0,5 m.
- The antenna cable shall be wired in an electric conduit.
- A crushing of cable shall be absolutely avoided.
- The minimal bend radius of the extension cable is 50 mm.
- As for the cable laying the use of an active pull-up device should be avoided, so to avoid any damages on the sheathing respectively on the connectors.

» COMMISSIONING

Radio sensors send time or event controlled telegrams to the receiver. The receiver verifies the incoming telegrams and output them directly via their interface. Each telegram allows a precise allocation and consists of the format: type of the telegram, data, sender-ID 32bit.

In order to assure a correct evaluation of the measuring values by the receiver, it is necessary to have the devices learned by the receiver. This is done automatically by means of a "learn button" at the sensor or manually by input of the 32bit sensor ID and a special "learning procedure" between sender and receiver. The respective details are described in the corresponding software documentation of the receiver.

» LED ERROR CODES

PWR	BUS	RAD	ERR	
■		X	●/■	faulty bus communication
○	●	○	●	faulty dipswitch setting
○	○	●	●	Error radio module

■ LED flashes

● LED permanently ON

○ LED OFF

» CONNECTION CONFIGURATION - STC65+ RS485-MODBUS

Factory default: RTU, Address 1, 9600Bd, Parity even, Version 32Rx/8Tx

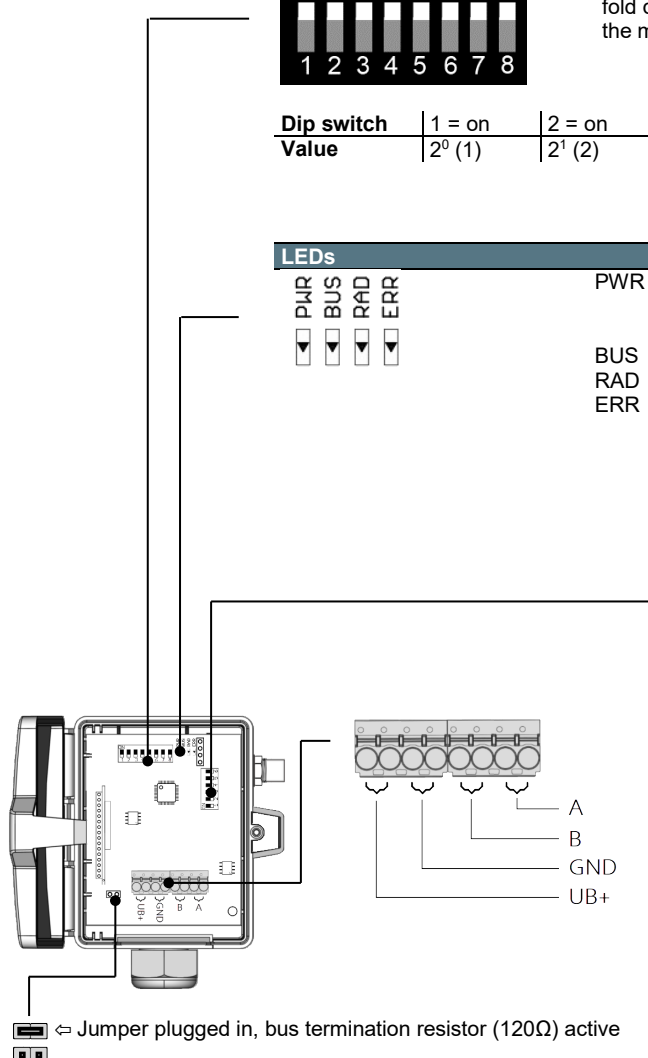

DIP 1.1 – 1.8 Address (binary coded)

ON

1	2	3	4	5	6	7	8
---	---	---	---	---	---	---	---

The address of the device is set binary coded in the range 1...247 via an 8-fold dip switch. The address 0 is reserved for a broadcast and is initiated by the master.

Dip switch	1 = on	2 = on	3 = on	4 = on	5 = on	6 = on	7 = on	8 = on
Value	2^0 (1)	2^1 (2)	2^2 (4)	2^3 (8)	2^4 (16)	2^5 (32)	2^6 (64)	2^7 (128)

LEDs

LED	Function
PWR	Power supply OK
BUS	LED permanently ON → Version 32Rx / 8Tx active LED flashes → 32Rx / 32Tx / 32VA active
RAD	Indicator RS485 data traffic
ERR	Indicator EnOcean radio traffic Indicator Error message

DIP 2.1

ON

1	2	3	4	5	6
---	---	---	---	---	---

1	Transmission mode
off	Modbus RTU
on	Modbus ASCII

DIP 2.2 - 2.3

ON

1	2	3	4	5	6
---	---	---	---	---	---

2	3	Baud rate
off	off	9600
on	off	19200
off	on	38400
on	on	57600

DIP 2.4 - 2.5

ON

1	2	3	4	5	6
---	---	---	---	---	---

When ASCII mode is enabled, EVEN or ODD parity must be selected. "No parity" is not available in ASCII mode.

4	5	Parity
on	off	even – 1-Stopbits
off	on	odd – 1 Stopbit
off	off	none – 2 Stopbit

DIP 2.6

ON

1	2	3	4	5	6
---	---	---	---	---	---

Rx = Recipient channels
Tx = Transmission channels
VA = Valve actuators (i.e. SAB)

6	Version
off	32Rx / 8Tx
on	32Rx / 32Tx / 32VA

⇔ Jumper plugged in, bus termination resistor (120Ω) active

A = TxD+ / RxD+ = A+ / non-inverted signal
B = TxD- / RxD- = B- / inverted signal

Interface description/ register specification



The configuration software and further information for parameterization of the Modbus gateway is available for download under the following link. Pay attention to the configured version. Depending on the setting (DIP 2.6), the appropriate documentation must be called up.

→ [Download *.zip](#)

» CONNECTION CONFIGURATION - STC65+ RS485-EVC

Factory default: Address 1, 9600Bd, Parity even, Compatibility mode EIN

DIP 1.1 – 1.6 Address (binary coded)

ON

1	2	3	4	5	6	7	8
---	---	---	---	---	---	---	---

The address of the device is set binary-coded in the range 0...63 via a 6-fold dip switch.

Dip switch	1 = on	2 = on	3 = on	4 = on	5 = on	6 = on
Value	2 ⁰ (1)	2 ¹ (2)	2 ² (4)	2 ³ (8)	2 ⁴ (16)	2 ⁵ (32)

DIP 1.7 – 1.8

ON

1	2	3	4	5	6	7	8
---	---	---	---	---	---	---	---

	2	3	Baud rate
	off	off	9600
	on	off	19200
	off	on	38400
	on	on	115200

LEDs

PWR	BUS	RAD	ERR	PWR	Power supply OK
<input type="checkbox"/>	<input type="checkbox"/>	<input type="checkbox"/>	<input type="checkbox"/>	BUS	Indicator RS485 data traffic
				RAD	Indicator EnOcean radio traffic
				ERR	Indicator Error message

DIP 2.1 – 2.2

ON

1	2	3	4	5	6
---	---	---	---	---	---

When ASCII mode is enabled, EVEN or ODD parity must be selected. "No parity" is not available in ASCII mode.

1	2	Parity
on	off	even – 1-Stopbits
off	on	odd – 1 Stopbit
off	off	none – 2 Stopbit

DIP 2.3

ON

1	2	3	4	5	6
---	---	---	---	---	---

To be able to parameterize the EVC gateway with the configuration software, the device must be in compatibility mode.

3	Compatibility mode
on	ON (Firmware V2.0.0)
off	OFF

DIP 2.4 – 2.6

ON

1	2	3	4	5	6
---	---	---	---	---	---

2	3	4	no function
reserved	reserved	reserved	reserved

A = TxD+ / RxD+ = A+ / non-inverted signal
 B = TxD- / RxD- = B- / inverted signal



By switching the dipswitch 2.3 the compatibility mode is deactivated/activated. This serves to be able to exchange older models easily. VLD/MSK telegrams, SMACK and various commands are not available. The answers to commands correspond to the firmware version 2.0.0.

Interface description



The configuration software and further information on parameterization of the EVC Gateway can be downloaded from the following link.

→ [Download *.zip](#)

» DIMENSIONS (MM)

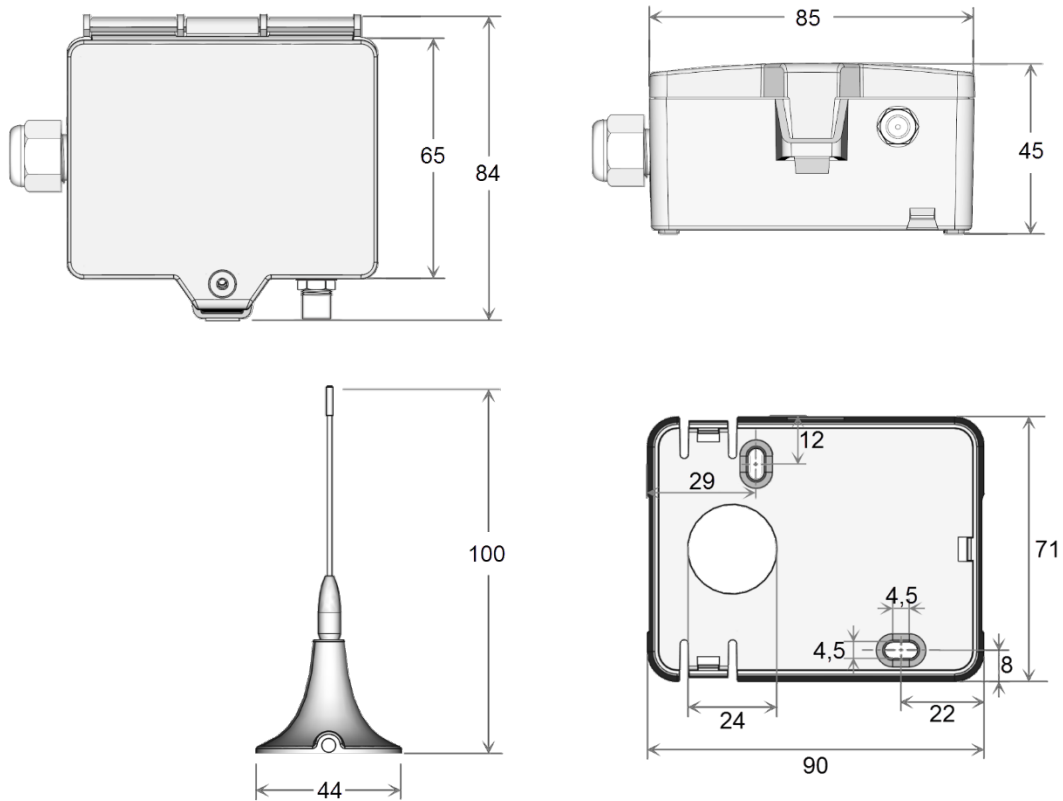

» ACCESSORIES (INCLUDED IN DELIVERY)

Mounting base

Item No. 631228

Mounting kit universal

Item No. 698511

• Cover screw + screw cover • 2 Rawlplugs • 2 Screws (countersunk head) • 2 Screws (rounded head)

» ACCESSORIES (OPTIONAL)

Antenna extension 10 m

Item No. 257206

Antenna extension 20 m

Item No. 257213

Antenna holder form L, 180x180 mm

Item No. 255097

Rawl plugs and screws

Item No. 102209